

TULEVAISUUS. PAIKKA JOSSA KUKAAN EI OLE OLLUT.

Pasi Vainikka
Johtava tutkija, VTT
Dosentti, LUT



**NEO
CARBON
ENERGY**

Puhdas liikenne Etelä-Karjalassa
Holiday Club Saimaa

30.1.2017

/ HIILI

/ SÄHKÖ

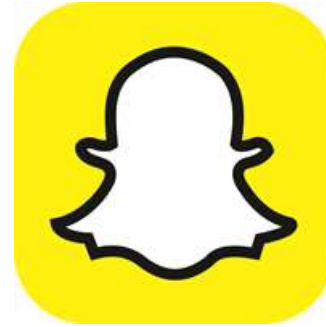

Google



NEO
CARBON
ENERGY



Alibaba Group



NEO
CARBON
ENERGY

5th Avenue, New York, April 15, 1900

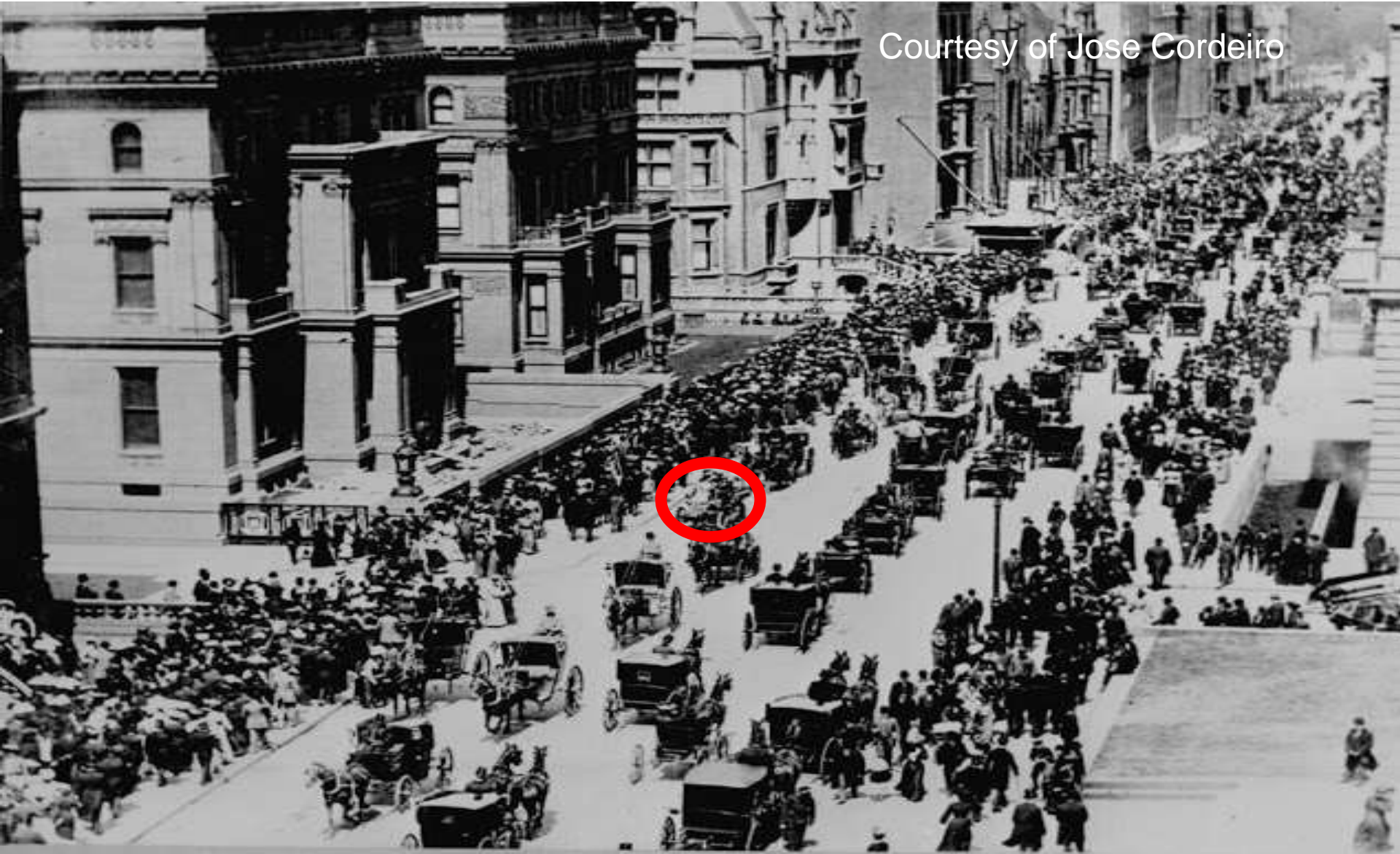

Courtesy of Jose Cordeiro

5th Avenue, New York, March 23, 1913



45 Billion tonnes of CO₂

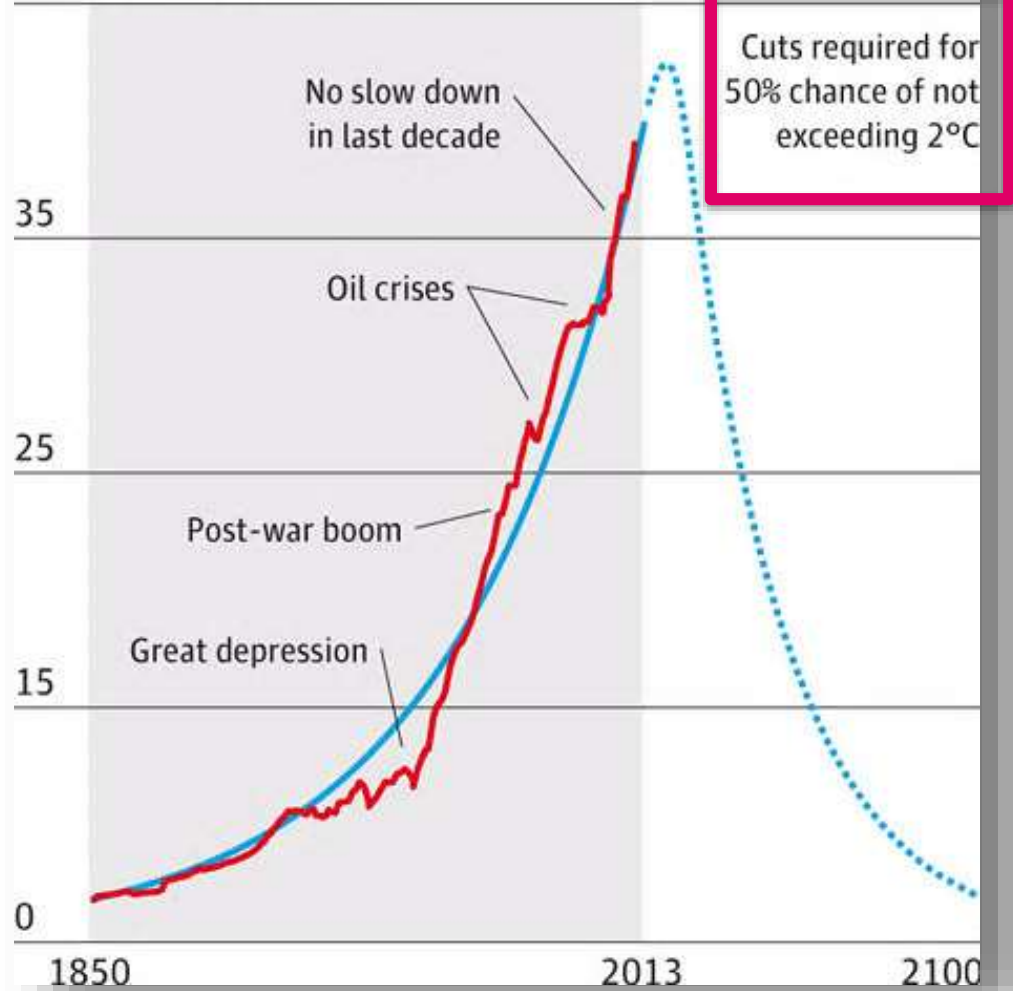

NEO
CARBON
ENERGY

Suuri sähköistyminen

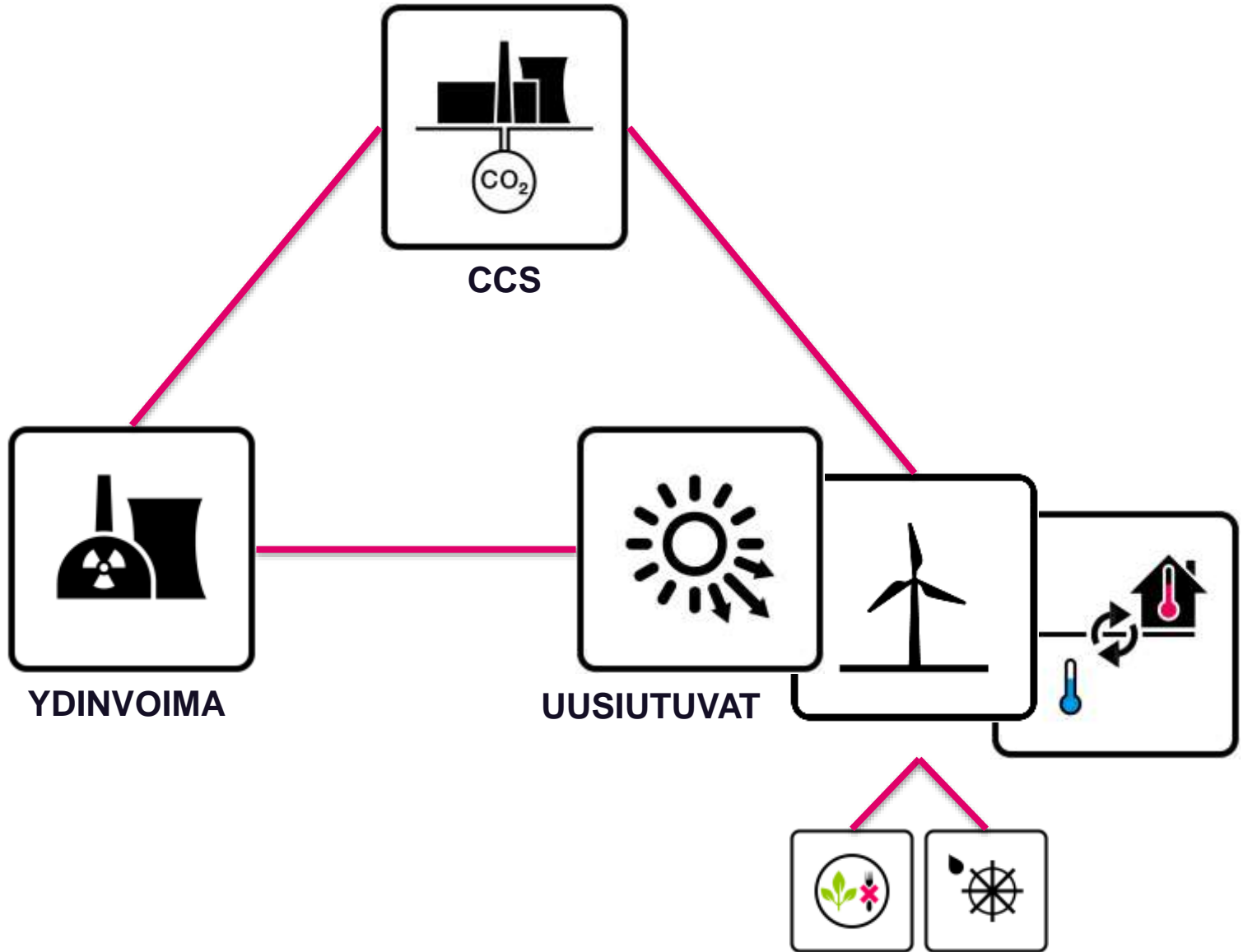

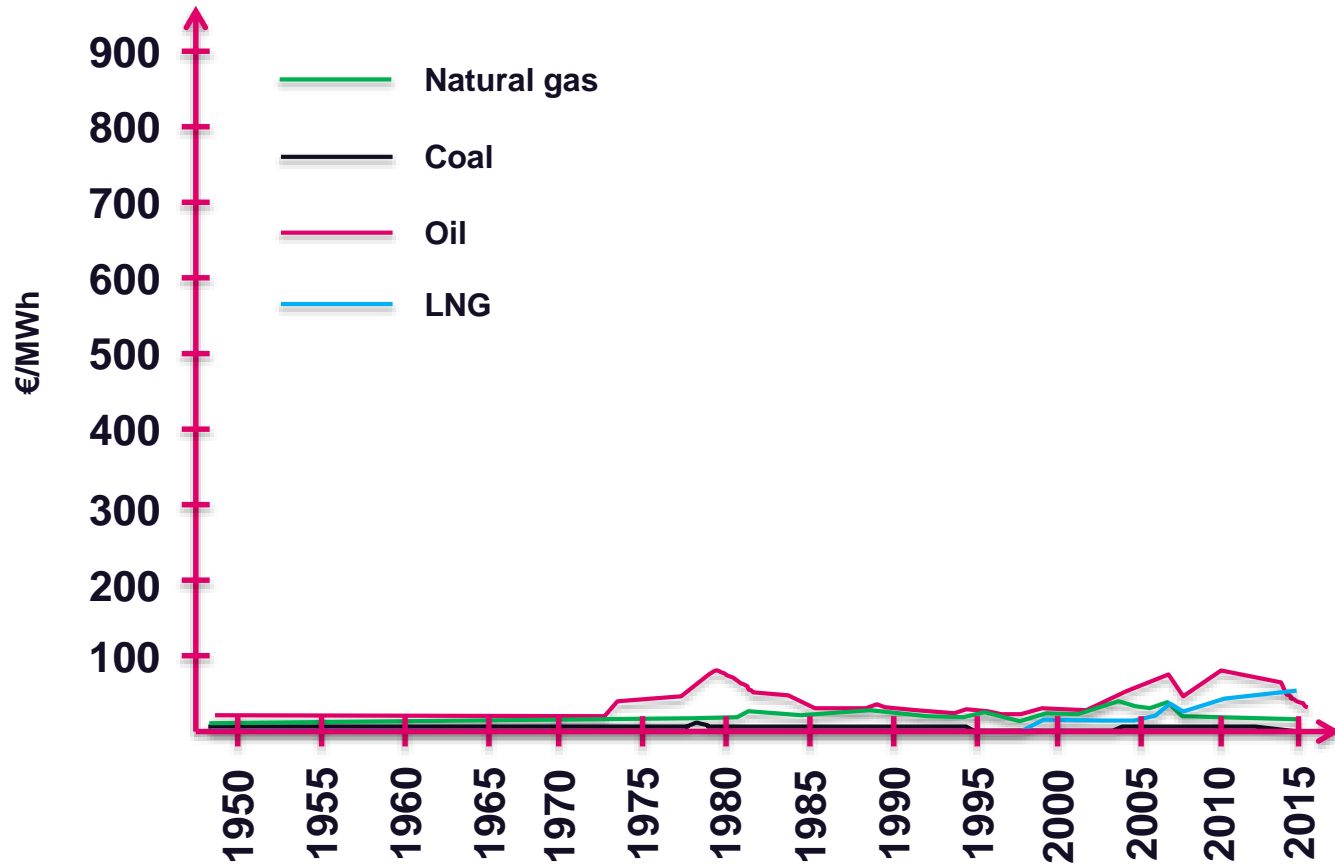

NEO
CARBON
ENERGY

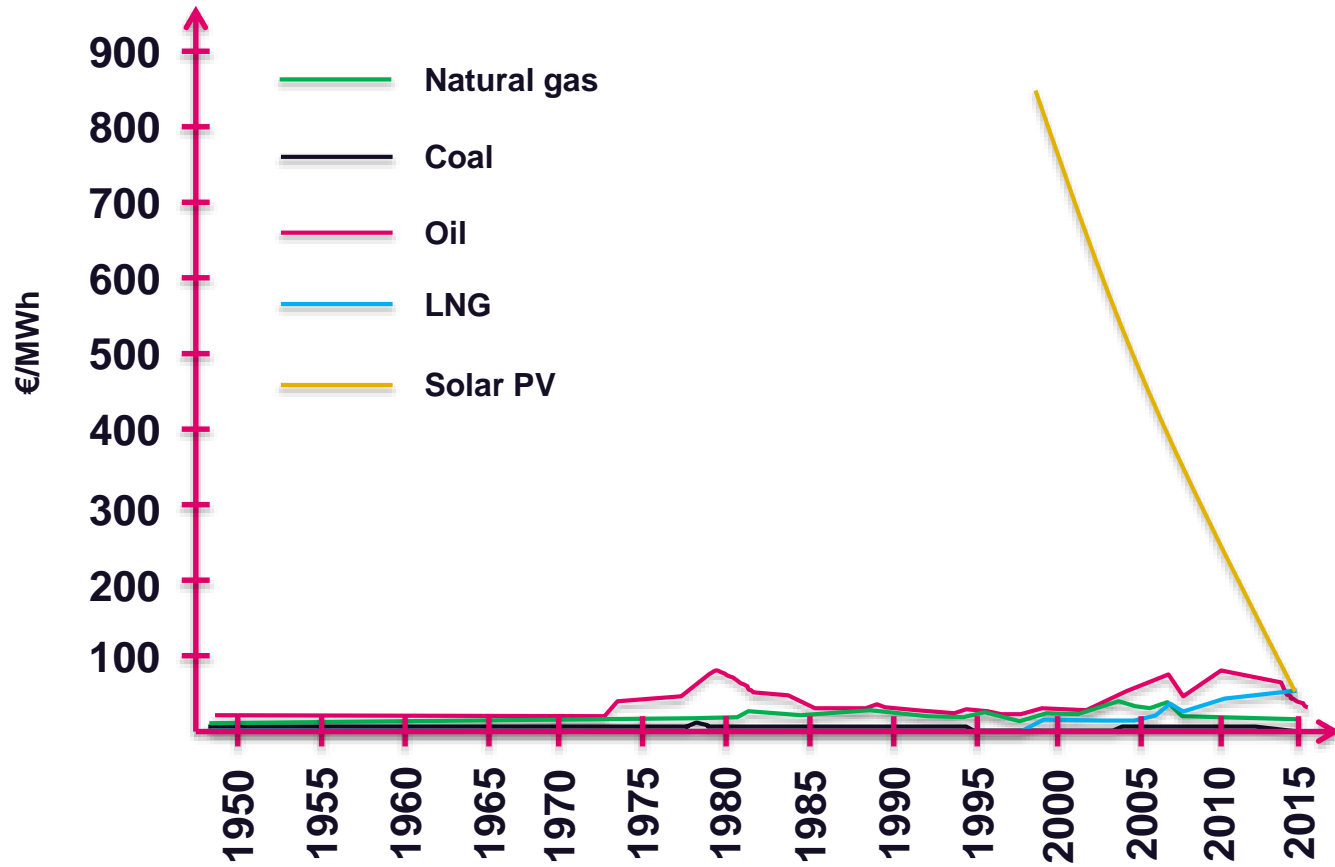

NEO
CARBON
ENERGY

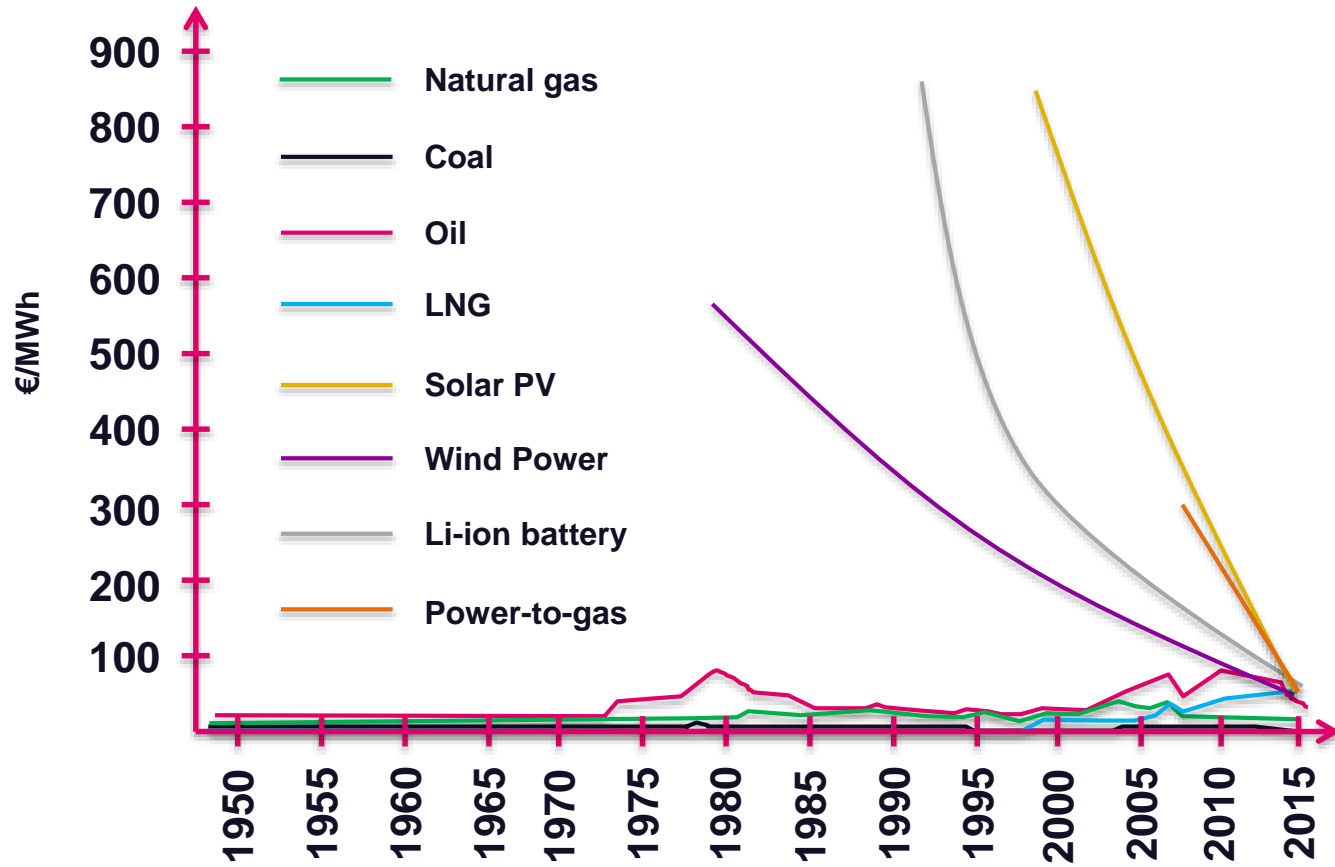

NEO
CARBON
ENERGY

**ONE-WAY
POWER
SYSTEM
TODAY**

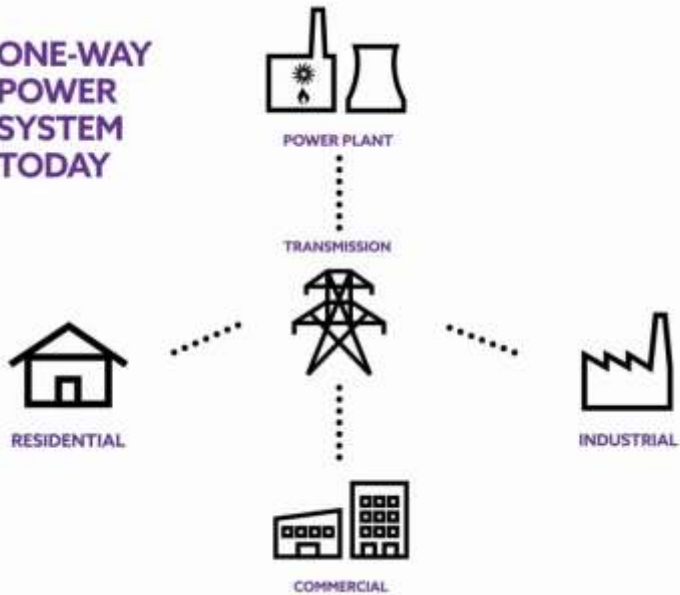

**FUTURE
ENERGY
CLOUD**

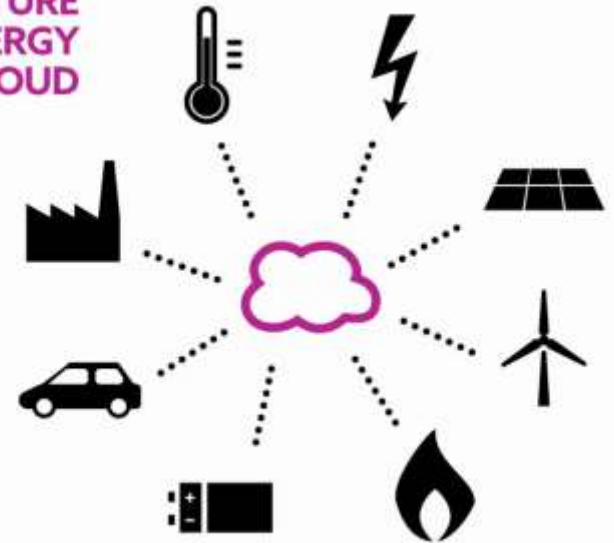

**NEO
CARBON
ENERGY**

Virusteoria



NEO
CARBON
ENERGY

Akku

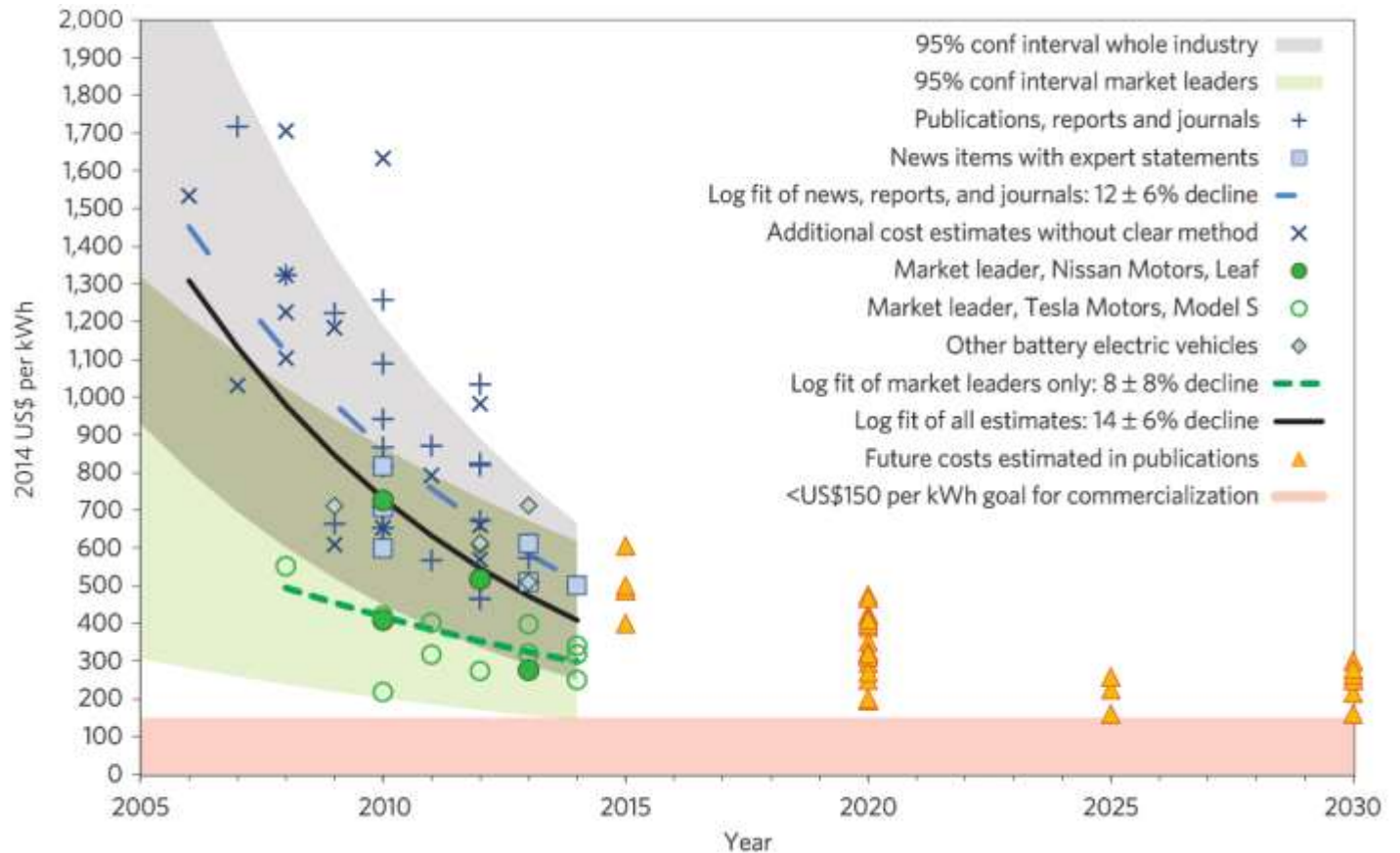

NEO
CARBON
ENERGY

Akku

BATTERY CELL COST

ABLE TO ACHIEVE
LOWER COSTS EARLIER
WITH **MUCH LESS**
CAPITAL AND VOLUME
DEPENDENCY



NEO
CARBON
ENERGY

Kustannus
energiavarastona
45 €/MWh

EV MODELS SOLD IN THE NORDICS



**NEO
CARBON
ENERGY**

TRUST IN RENEWABLE.



NEO
CARBON
ENERGY



Available online at www.sciencedirect.com

ScienceDirect

Energy Procedia 99 (2016) 25 – 34

Energy
Procedia

10th International Renewable Energy Storage Conference, IRES 2016, 15-17 March 2016, Düsseldorf, Germany

The role of energy storage solutions in a 100% renewable Finnish energy system

Michael Child*, Christian Breyer

Lappeenranta University of Technology, Skinnarilankatu 34, 53850 Lappeenranta, Finland

Abstract

A 100% renewable energy scenario was developed for Finland in 2050 using the Energy least-cost configuration. Hourly data analysis determined the roles of various energy storage solutions. Storage represented 15% of end-user demand. Thermal storage discharge was 4% of end-user demand, 21% of demand was satisfied by electricity storage discharge, with the majority (87%) of connections. Grid gas storage discharge represented 26% of gas demand. This suggests that storage is a part of a 100% renewable Finnish energy system.

© 2016 The Authors. Published by Elsevier Ltd. This is an open access article under the CC BY-NC-ND 4.0 International license (<http://creativecommons.org/licenses/by-nc-nd/4.0/>).

Peer-review under responsibility of EUROSOLAR - The European Association for Renewable Energy Research.

Keywords: energy system modeling; storage solutions; 100% renewable energy; Finland; vehicle-to-grid

1. Introduction

Variability and uncertainty are inherent qualities of energy systems as supply and demand vary over time, space and sometimes in unpredictable ways. The challenge of meeting demand with renewable energy resources requires a high level of flexibility, often provided by energy resources, particularly storage.



NEO
CARBON
ENERGY



Open your mind. LUT.

Lappeenranta University of Technology

Renewable energy scenarios of South Karelia in 2030 and 2050

Jori Lindgren, Jero Ahola

/ HIILI

/ SÄHKÖ

News > World > Europe

Germany pushes to ban cars within next 20 years

The resolution urges the European Commission to impleme

Shehab Khan | @shehabkhan | Monday 10 October 2016 | 359 comments



View of the Berlin skyline seen from Potsdamer Platz to Alexanderplatz. Getty Images

Germany's federal council, the Bundesrat, has passed a resolution calling for a ban on combustion engine cars by 2030.



Oslo temporarily bans diesel cars to combat pollution

Norway's two-day city centre ban angers motorists who were encouraged to buy diesel vehicles in 2006



Westminster council to become first to charge extra to park diesel cars

In trial aimed at cutting air pollution, diesel motorists parking in Marylebone will pay an additional 50%, or £2.45 extra an hour



Council says money raised through "polluter pays" scheme will be spent on sustainable transport. Photograph: Yui Mok/PA

to ban diesel



GETTY IMAGES

nce on the use of diesel

Global oil demand by sector



World Oil Outlook. OPEC 2015.

http://www.opec.org/opec_web/static_files_project/media/downloads/publications/WOO%202015.pdf

DISTILLATION OF CRUDE OIL

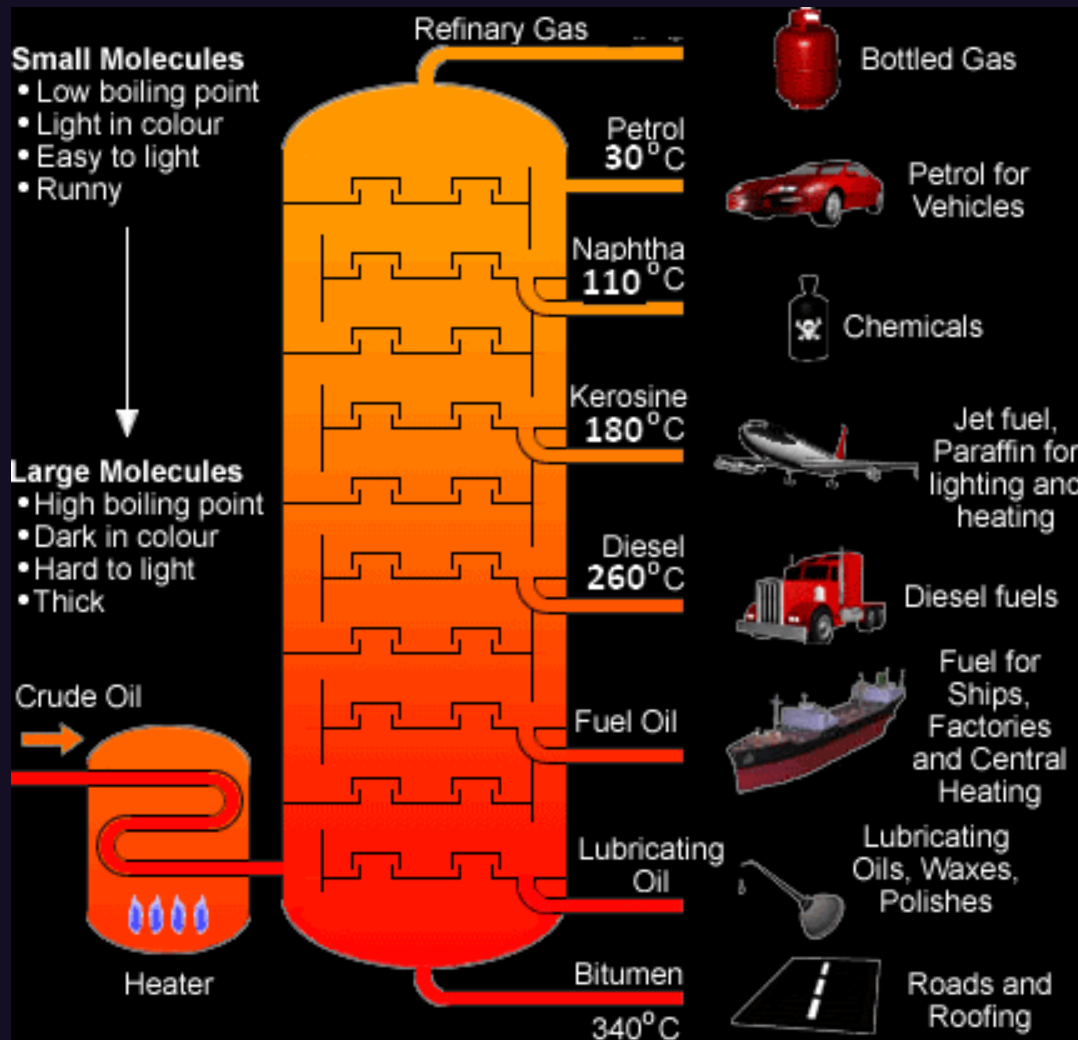

**NEO
CARBON
ENERGY**

TRUST IN RENEWABLE.

/ POWER-TO-X

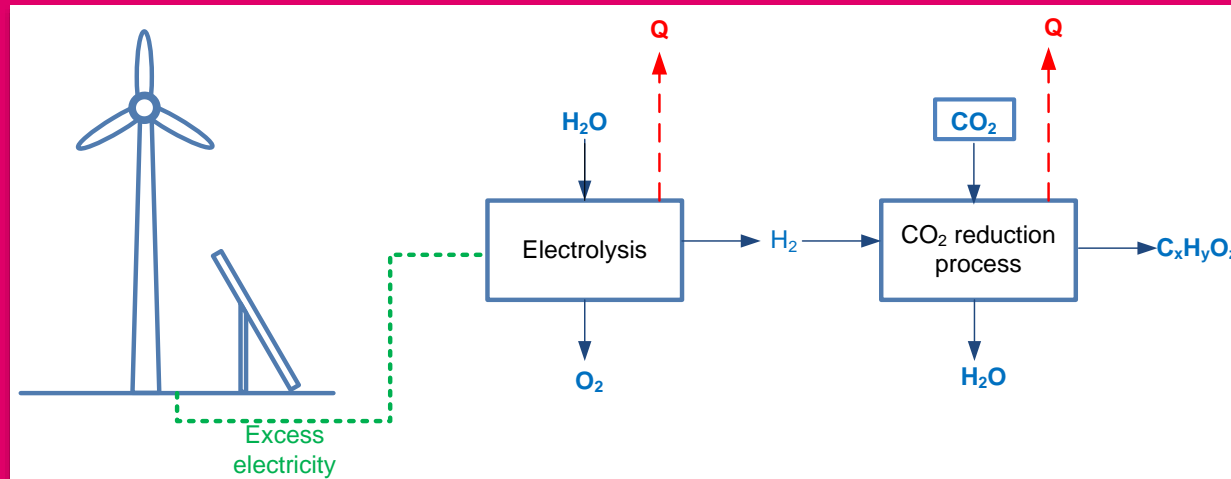

- Excess electricity to chemicals, fuels and materials by using CO₂
- Replacing crude oil, gas and gas condensates
- ”sähköpolttoaineet”



NEO
CARBON
ENERGY

SOLETAIR

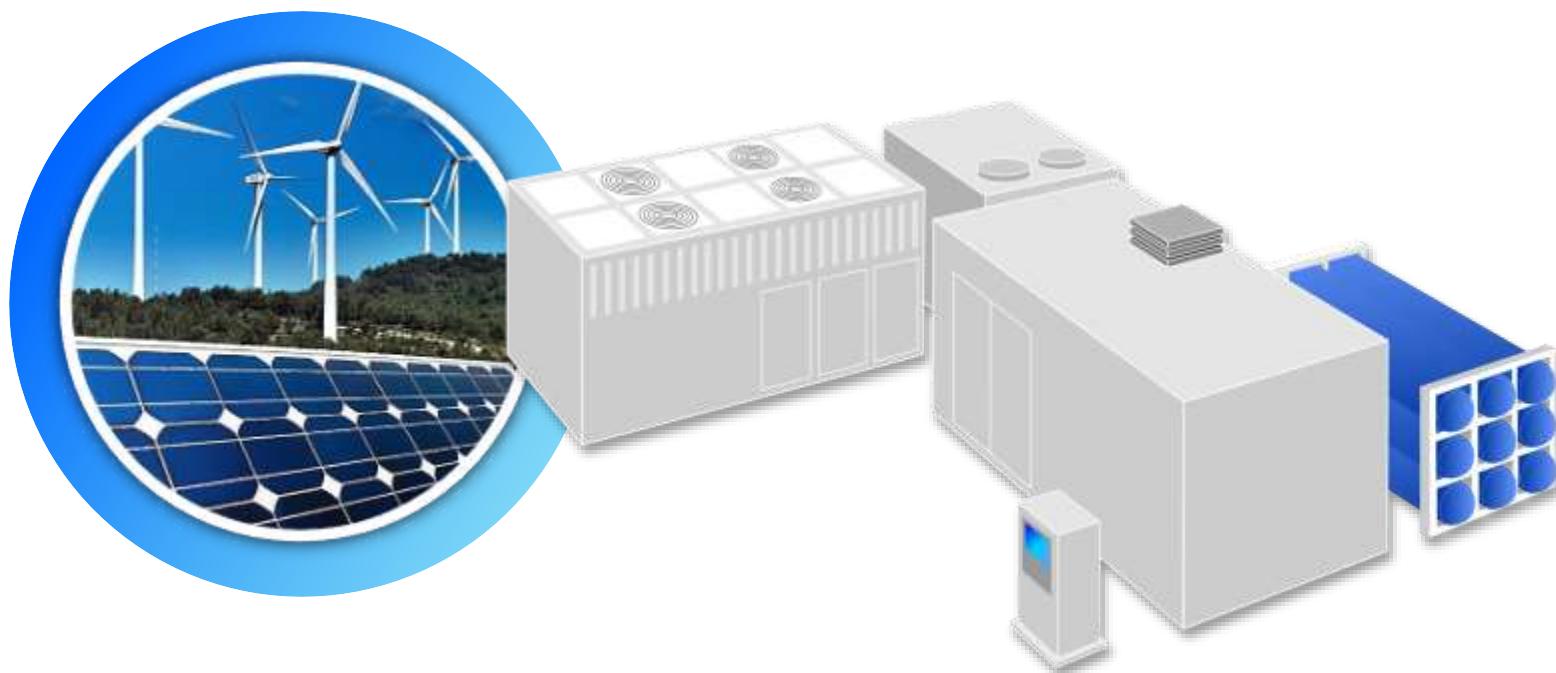

NEO
CARBON
ENERGY



/ BIOECONOMY+

/ CO₂ PÄÄSTÖT

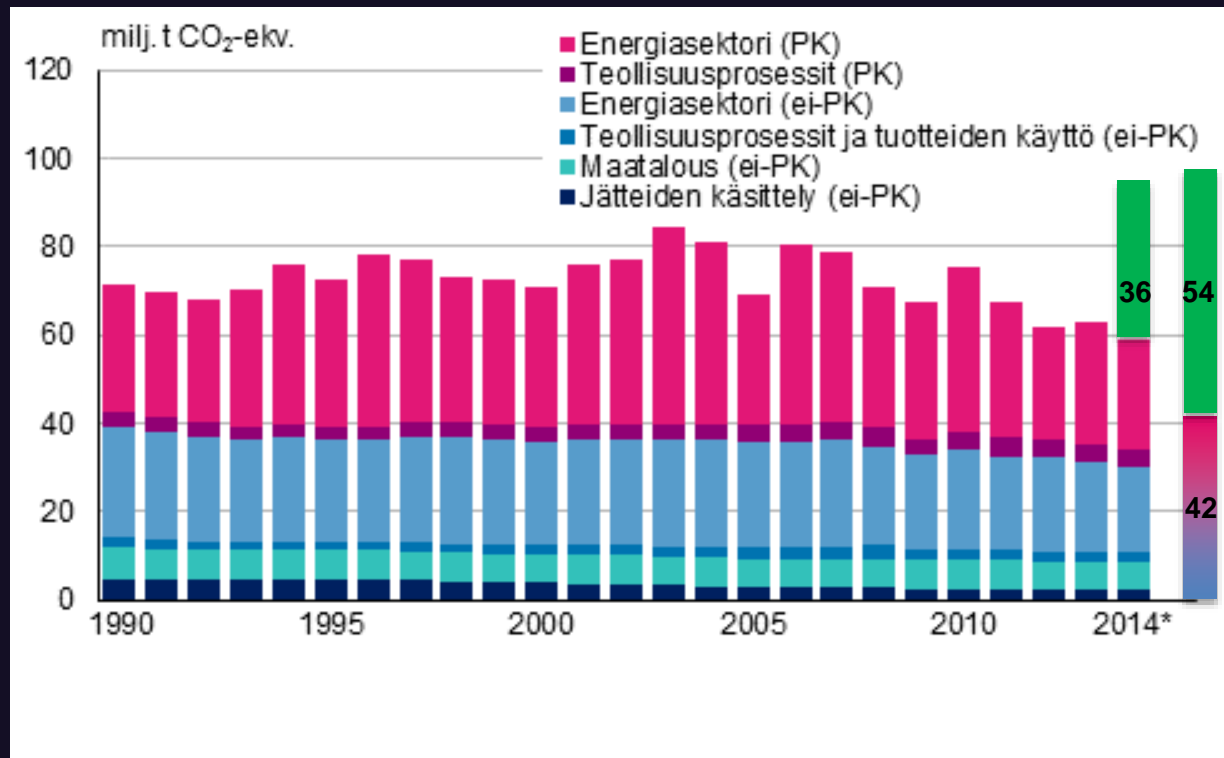

- Hiilitehokkuus: Sellutehdas 50%
Puu-dieseltehdas 33%



NEO
CARBON
ENERGY

TRUST IN RENEWABLE.

/ HIILI

/ SÄHKÖ

TULEVAISUUS. PAIKKA JOSSA KUKAAN EI OLE OLLUT.

Pasi Vainikka
Johtava tutkija, VTT
Dosentti, LUT



**NEO
CARBON
ENERGY**

Puhdas liikenne Etelä-Karjalassa
Holiday Club Saimaa

30.1.2017